



Balmoral HydroClearTM

Sewage treatment plant

An environmental asset

A summary of what makes the HydroClear so special



Class-leading performance

The HydroClear produces an astonishing **pollutant removal level of 97%**. Carrying full CE accreditation to BS EN12566-3, final values are achieved for BOD, SS and NH₄-N of 10:13:6mg/l respectively.

Lower operating costs

With its unprecedented 24-month service period and enhanced capacities the HydroClear can dramatically reduce long term operating costs. This is achieved through the inherent reliability of the simple but effective design rather than using complex systems that require frequent maintenance and desludging to achieve optimum performance.

Easy installation

Further benefits are realised from the outset with optimised design characteristics meaning the 6-pop model can be installed using a 2.5-tonne mini-digger rather than the 7 or 12-tonne machines required for traditional plants. These design values are reflected across the entire HydroClear range resulting in simple, cost effective installation with minimal damage to the surrounding area.

Power failure default

Even if the power fails the HydroClear will continue performing as a septic tank to ensure continued environmental protection.

Silence is golden

High performance diaphragm blowers are used across the full range of HydroClears providing virtually silent operation.

Odour minimisation

Hermetically sealed and market leading performance means the HydroClear effectively combats odour production.

6-50-pop options

The HydroClear is available in 6, 12, 30, 40 and 50-population models, in single or multitank designs, depending on size, offering a highly flexible solution to space-limited sites.

Balmoral HydroClear™

Sewage treatment plant

High performing, cost effective sewage treatment plant

Sizes and dimension

Balmoral HydroClear 6-pop



Balmoral HydroClear 30-pop*

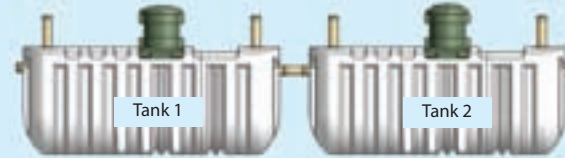

Balmoral HydroClear 12-pop



Balmoral HydroClear 40-pop*

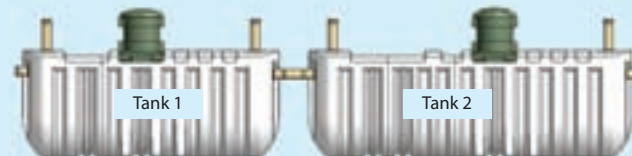

Balmoral HydroClear 20-pop



Balmoral HydroClear 50-pop*



Key dimensions

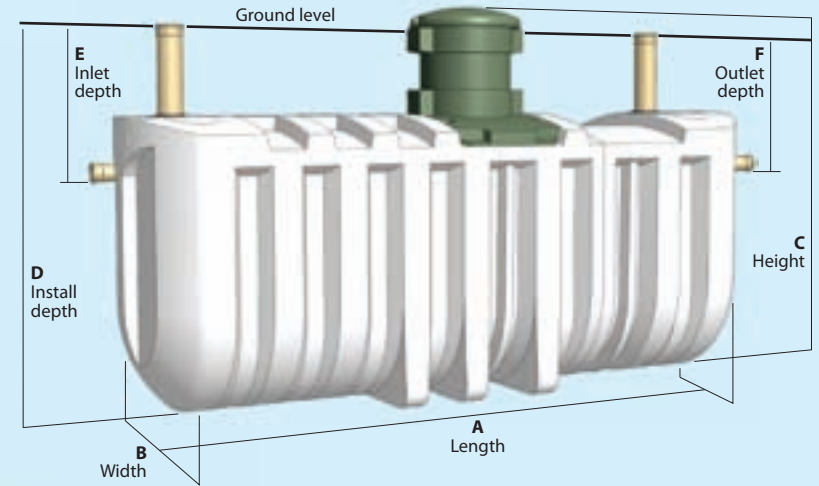

* Installations can be in line as shown or side by side as conditions dictate.

Tank pop size	Total capacities Litres	Tank 1						Tank 2						Tank 3						
		A Length	B Width	C Height	D Install depth	E Inlet depth	F Outlet depth	A Length	B Width	C Height	D Install depth	E Inlet depth	F Outlet depth	A Length	B Width	C Height	D Install depth	E Inlet depth	F Outlet depth	
6-pop	4400	3400	1250	2635	2450	1000	1050													
12-pop	5950	4500	1400	2635	2450	1000	1050													
20-pop	7960	5680	1400	2635	2450	1000	1050													
30-pop	11410	4500	1400	2635	2450	1000	1050	4500	1400	2635	2450	1050	1050							
40-pop	14920	4500	1400	2635	2450	1000	1050	5680	1400	2635	2450	1050	1050							
50-pop	18400	5680	1400	2635	2450	1000	1050	4500	1400	2635	2450	1050	1050	3400	1250	2635	2450	1050	1050	

Raising the benchmark for sewage treatment plant across the EU

Happily, for everyone, domestic wastewater treatment has come a long way since the days of cess pits and septic tanks.

Rigorous effluent quality legislation has driven the design of more effective systems resulting in today's modern package treatment plant.

The latest of these drivers takes the shape of European-wide product testing standardisation. Raising the benchmark for domestic sewage treatment plants, BS EN 12566-3 brings harmony across the EU.

Balmoral Tanks' third generation sewage treatment plant, the HydroClear™, represents significant progress for the domestic wastewater industry.

Contemporary design engineering and analysis software and state-of-the-art manufacturing facilities combine to create this unique product which dominates the domestic market with a **pollutant removal level of 97%**.

Market-leading performance, easier installation and competitive through-life costs, enhanced transportability and storage, product reliability and robustness are all qualities that were factored into the HydroClear design brief. Factors that were critical in achieving full CE accreditation in 2008.

“Balmoral Tanks’ third generation sewage treatment plant, the HydroClear, represents significant progress for the domestic wastewater industry.”

 Balmoral Tanks Ltd Balmoral Park, Loirston, Aberdeen AB12 3GY 09 EN 12566-3	“Balmoral HydroClear™ sewage treatment plant”	
	Nominal hydraulic daily load:	1.20-10m ³ /d
	Material:	Polyethylene
	Watertightness (water test):	pass
	Crushing resistance:	pass
	Treatment efficiency:	COD 91.2%
	(nominal sequences)	BOD 96.6%
		SS 94.7%
		NH ₄ -N 85.8%
	Electrical consumption (6pop):	1.8 kWh/d



An environmental asset

Balmoral HydroClear™

Sewage treatment plant



How does it work?

An aerated biological system, the HydroClear benefits from a moving bed biological reactor, or MBBR, at its core. A new process in the package wastewater market, MBBR technology embraces the benefits of fixed film media processes without suffering their downfalls.

Overgrowth of bacteria leading to 'channelling' is an issue with common process designs such as submerged aerated filters (SAF), rotating biological contactors (RBC) or trickling filter (TF) designs.

Unlike conventional media beds, MBBR systems are self cleaning and unable to become blocked through channelling. Media interactions produce a sloughing effect that removes excess bacteria thus ensuring continuous re-growth, optimising overall reactor efficiency.

The Balmoral HydroClear system incorporates a three chamber design, ie, primary settlement, aeration chamber and final settlement.

Within the primary settlement chamber, large solids are removed by settlement and flotation. An accumulation forms at the base of the tank and is removed by desludging.

The clarified water then passes to the biological reactor where it is treated to remove the dissolved constituents. Mobile media elements support large bacterial populations within the reaction chamber while induced air promotes complete mixing ensuring that full treatment is achieved.

The treated effluent and sloughed off bacteria flows into the final settlement chamber where any remaining small solids are removed prior to the clarified effluent being discharged from the plant.

An environmental asset

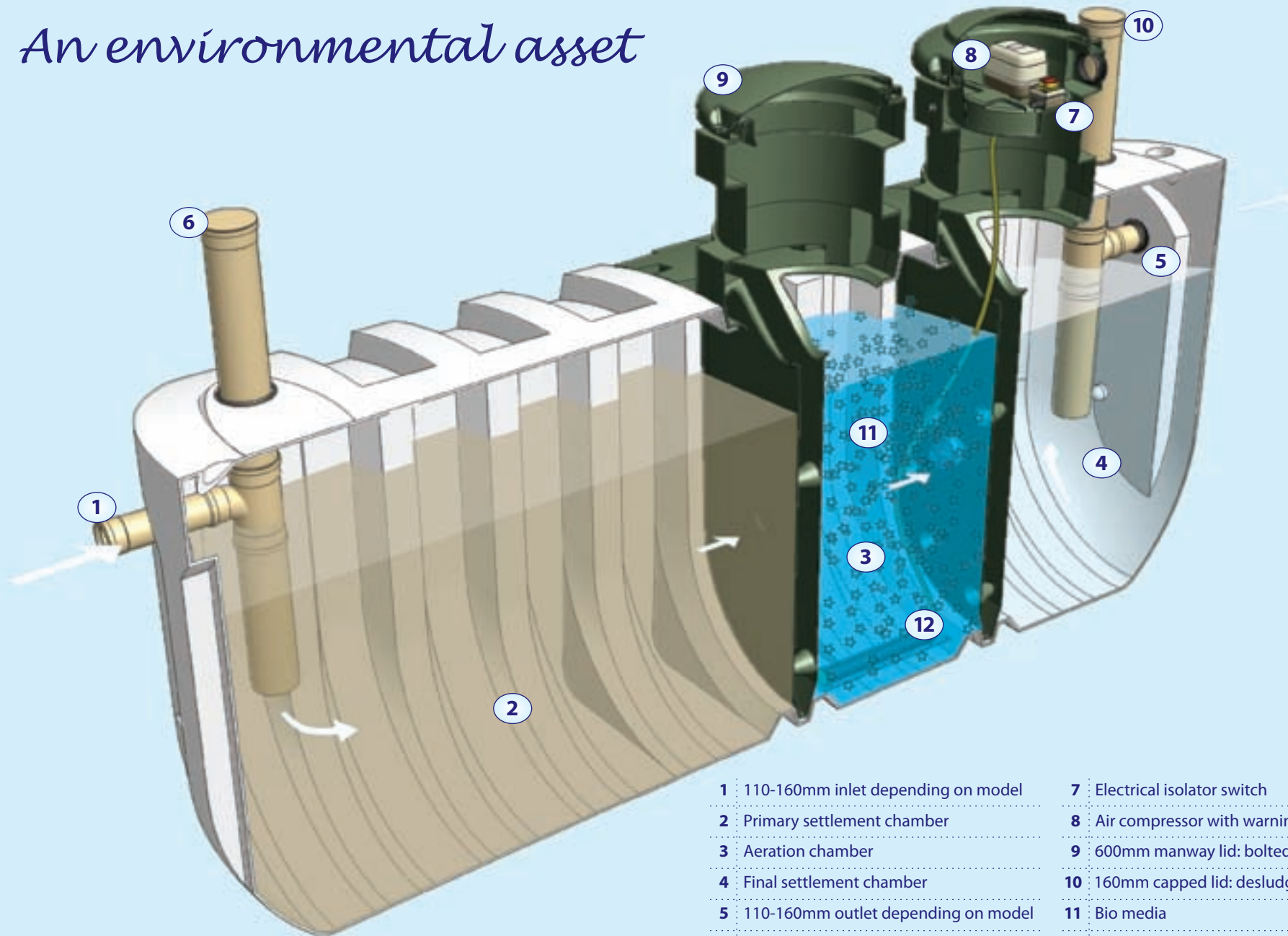

- | | | | |
|---|-------------------------------------|----|---|
| 1 | 110-160mm inlet depending on model | 7 | Electrical isolator switch |
| 2 | Primary settlement chamber | 8 | Air compressor with warning system (240V) |
| 3 | Aeration chamber | 9 | 600mm manway lid: bolted down and sealed |
| 4 | Final settlement chamber | 10 | 160mm capped lid: desludge point |
| 5 | 110-160mm outlet depending on model | 11 | Bio media |
| 6 | 160mm capped lid: desludge point | 12 | Bubble diffuser |

Why installing a Balmoral HydroClear makes environmental and economic

The HydroClear is Balmoral's third generation treatment plant and the result of an intensive three year research, development and testing programme.

Design objectives included improved performance, running costs, installation, haulage and storage, making the HydroClear a natural choice for specifiers, installers and end-users.

Performance and reliability

A new profile

The flow characteristics and settlement of wastewater material is profoundly affected by the shape of the vessel.

The HydroClear's performance is helped by the smooth curved lines of the radius base which was achieved using the latest 3D design modelling software. This allows for efficient settlement and desludging as well as demonstrating effective flow characteristics through the plant.

Outstanding performance leads to CE accreditation

The HydroClear is now established as having a market leading pollutant removal level of 97% BOD (Biological Oxygen Demand) a measure of organic content. The performance was verified during a 38-week test period at an independent test facility and the award of full CE certification in accordance with BS EN12566-3.

Servicing and desludging

Less servicing required

The HydroClear incorporates a self cleaning treatment chamber, itself requiring no servicing. Unlike static media beds, the MBBR process is self optimising and bacterial growth is controlled through the sloughing media interaction. Reactor conditions are optimised for best water/bacteria mixing and no maintenance of the media is required - unlike fixed systems such as SAF, RBC and TF

designs which, if blockage occurs, need to be cleaned using a jet spray.

The diaphragm air blowers are the main component requiring servicing. They run virtually silently at low temperatures using minimal power. As a result, the workings of these blowers have an extensive field life and servicing is limited to an air filter and diaphragm inspection, both of which are easily accomplished by the user.

Servicing of the systems is required at 24-month intervals, longer than alternative products by up to 18 months. The HydroClear is designed to offer one of the longest maintenance intervals of any package plant so, with a typical maintenance visit costing up to £200 (for single household), represent a considerable saving over traditional plants.

Longer desludging intervals

Despite what is printed in literature for recommended desludging intervals, it is the actual tank storage capacity that is important. It is therefore important to be aware of smaller sized plants promising comparable desludging intervals. The HydroClear has large primary and final settlement capacities meaning that intervals are maximised and significantly longer than many competitor products. At approximately £200 per visit for a 6-pop system, big savings in ongoing costs can be achieved.

Where the sludge level of the plant fills at a slower rate it is possible to extend the tank desludging interval. This should be determined on a site specific basis and Balmoral Tanks provides customers with a sludge gauge to test their plants.

Using the gauge, HydroClear owners can determine and potentially extend their desludge intervals well beyond that of similarly sized plants. This creates the opportunity for further cost savings in through life costs.

If the power supply to the HydroClear should fail, the system will revert to a fully sized septic tank allowing it to continue the function of pollutant removal. Alternative products may be vastly undersized to cope with these circumstances effectively.

HydroClear owners determine their own desludge requirements meaning potential cost savings of at least £200 every year.



Delivery and installation

Modular design aids delivery

Site limitations frequently prevent articulated truck access which can hamper deliveries of large single-vessel treatment plant.

The HydroClear 6, 12 and 20-pop models are delivered as compact single units while the 30, 40 and 50-pop models are designed as modular, easily transported, multi-vessel options.

All models are therefore easily transported even to the most inaccessible sites and offloading is possible using smaller sized diggers or forklift trucks with a reduced likelihood for the requirement for special access or expensive cranes.

Further benefits are realised with multiple configuration options for the larger plants. The 50-pop vessels, for example, can be arranged side by side, end to end or in an 'L' shape optimising the available site space.

Shallow dig, less damage

The HydroClear's slim profile means that smaller diggers can be used during installation. Compared to conventional cylindrical, conical or box shaped tanks that require larger excavation, the HydroClear can be economically installed and cause less damage to the surrounding area.

The relatively shallow tank depth also minimises the chance of hitting bedrock or being affected by the water table compared to traditional designs. The HydroClear's depth of 2.45m provides healthy aeration for treatment whilst maintaining the required invert depth to the inlet pipe.

Added value design

Minimal visual impact

Aesthetically pleasing and secure, the HydroClear's 600mm green manways are utilised for maintenance access. These small, low profile covers have much less visual impact compared to large GRP covers on alternative products.

It can take the knocks

The Balmoral HydroClear is manufactured using high density polyethylene (HDPE) which is proven to be highly impact resistant during transportation, storage and installation compared to GRP alternatives which are prone to cracking if not handled with great care.

Installation

Locating your sewage treatment plant

Sewage treatment plant for a single household should be sited 15m from the house. Approval and agreement should be sought from your local authority as early as possible. Although the HydroClear is virtually odour-free, please also consider the prevailing wind direction when choosing your site.

Installations serving more than one building should be located at least 25m from habitable buildings. Some local authorities may allow HydroClears to be installed somewhat closer, but this needs to be checked and approved locally.

Don't situate your treatment plant close to a driveway, roadway or anywhere else that presents a risk of superimposed loads and remember - good access must be available for the tanker to empty your plant.

Site levels

Be sure to survey the site and check levels and the fall on the drain carefully. The Balmoral HydroClear is designed to cater for a drain invert depth of 1m but this can be reduced to 750mm or increased using a Balmoral-supplied extension to suit specific site requirements.

After sales service

Balmoral Tanks offers a nationwide service to cover all aspects of maintenance on Balmoral products. Packages can be tailored to your requirements from basic maintenance contracts, including on-going support and advice from legislative bodies, through to emergency call-out.



An environmental asset

“The HydroClear was a delight to install. The shallow depth and ease of handling also meant less damage to the surrounding area.”

Dave Bichan, Coldstream Mini-Diggers

Balmoral Group

Balmoral Group Holdings Ltd is a privately owned business headquartered in Aberdeen, UK, and has been providing solutions to the civil and environmental, building and energy sectors since 1980.

The enterprise has been built upon research, development and technical innovation. It is this commitment to progress that has helped the company achieve its status as a market leader in its chosen fields of operation.

The company has, for a number of years, successfully operated manufacturing processes at Balmoral Park which are approved and strictly regulated by the Scottish Environment Protection Agency under Part B of the Environmental Protection Act 1990.

Quality Assurance

Balmoral Tanks Ltd is certified to BS EN ISO 9001. The company's QA manuals are available for examination by all clients.

Balmoral Tanks Ltd

Balmoral Tanks Ltd, a division of Balmoral Group Holdings Ltd, is a leading European engineering design and manufacturing company.

As a result of significant investment in people and plant, the company produces what is believed to be the most comprehensive range of tank products available from a single source in the EU.

Civil engineering, wastewater treatment, drainage, fuel oil containment, bulk liquid and potable water storage sectors are all key sectors for the company.

Visit balmoraltanks.com for a comprehensive overview of the company and its products.



FM518297
Balmoral Tanks



Why installing a Balmoral HydroClear will save you thousands of pounds

Desludging intervals

A number of products on the market state 12-month desludging intervals, similar to the HydroClear 6-pop. However, the primary settlement capacities of some of these products could be smaller than the HC6 by as much as 66%. Unless accounted for by special process design this can result in desludging being required three times more frequently than the HydroClear. Similar circumstances may also be found in ranges above 6 pop.

Using the Balmoral sludge gauge, end-users can accurately measure sludge build up. Where reduced loadings exist, the HydroClear can operate safely with longer desludging intervals in comparison to similar sized products.

Servicing

The Balmoral HydroClear has been specifically designed to operate round a 24-month service interval; one of the longest available in the market.

The simplicity of the system also gives the end-user an option to service their plant using accredited engineers or perform a self service using Balmoral supplied kits. Either choice means paying less in service costs over the product's lifetime.

Operating cost calculator

Visit balmoralhydroclear.com to compare the life cycle costs of alternative products with the Balmoral HydroClear.



Balmoral HydroClear 6-pop 10 year maintenance costs		Comparable treatment plant 10 year maintenance costs	
End of year one			
Two-yearly service by owner	£ NR	£ 200	Annual engineer service
Two-yearly desludge	NR	200	Annual desludge
Total first year cost	0	400	Total first year cost
End of year two			
Two-yearly service by owner (service kit)	50	200	Annual engineer service
Two-yearly desludge	200	200	Annual desludge
Cumulative two year costs	250	800	Cumulative two year costs
End of year three			
Two-yearly service by owner	0	200	Annual engineer service
Two-yearly desludge	0	200	Annual desludge
Cumulative three year costs	250	1200	Cumulative three year costs
End of year four			
Two-yearly service by owner	50	200	Annual engineer service
Two-yearly desludge	200	200	Annual desludge
Cumulative four year costs	500	1600	Cumulative four year costs
Cumulative six year costs	750	2400	Cumulative six year costs
Cumulative eight year costs	1000	3200	Cumulative eight year costs
Cumulative ten year costs	1250	4000	Cumulative ten year costs

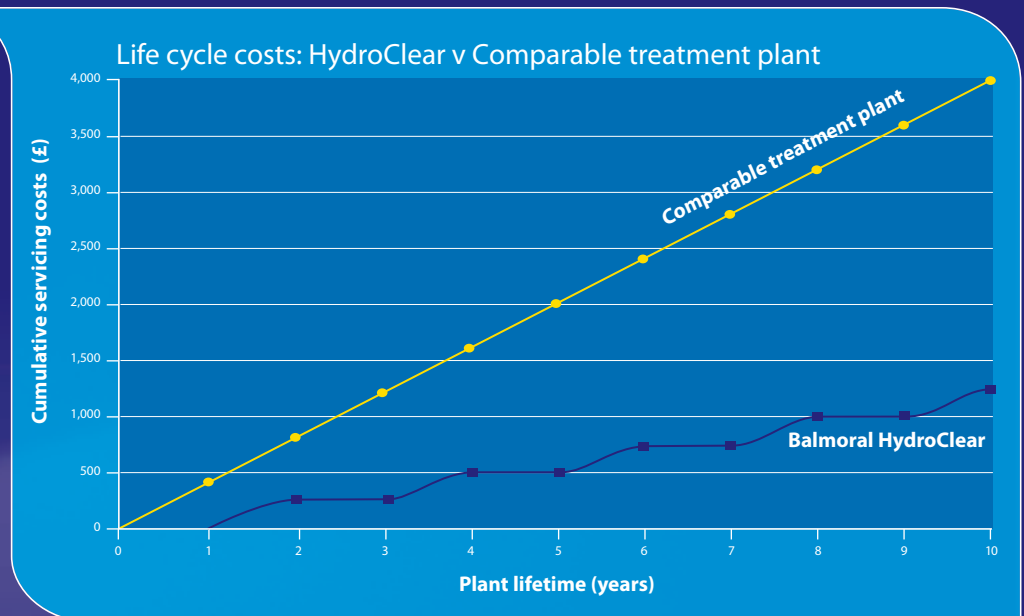

It has been assumed that the desludge interval for the HydroClear will be twice as long as the comparable product and self servicing will be carried out on the HydroClear every two years. The HydroClear's actual desludge interval may be longer than this depending on usage.

Balmoral Tanks Ltd

Balmoral Park, Loirston
Aberdeen AB12 3GY, Scotland

Tel	+44 (0)1224 859250
Fax	+44 (0)1224 859123
Email	hydroclear@balmoral.co.uk
Web	www.balmoralhydroclear.com

Balmoral Tanks Ireland

Tel	+44 (0)7500 797047
Tel/Fax	+44 (0)2890 286868
Email	tanks@balmoral.co.uk



FM518297
Balmoral Tanks

